

## Vertical Control Gap Tie

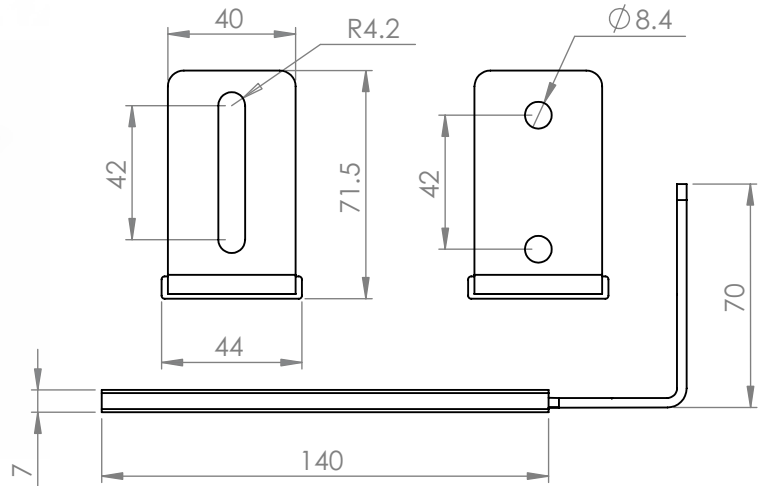

### DESCRIPTION

Vertical control gap tie for brick block work. This tie will retain masonry integrity against lateral wind loads, de bonding slide will absorb differential movement.

### FEATURES

- Clay brick / block
- Increased bond strength
- High strength vertical control gap tie
- Tested to a control gap of 20mm
- Universal applications
- Australian design & tested AS/NZS 2699.2:2020

### CORROSION CHARACTERISTICS

Hot dipped galvanising (R3)  
 Stainless steel 316L (R4)  
 Conforms to corrosion resistance set by AS/NZS 2699.2:2020 / AS 3700.

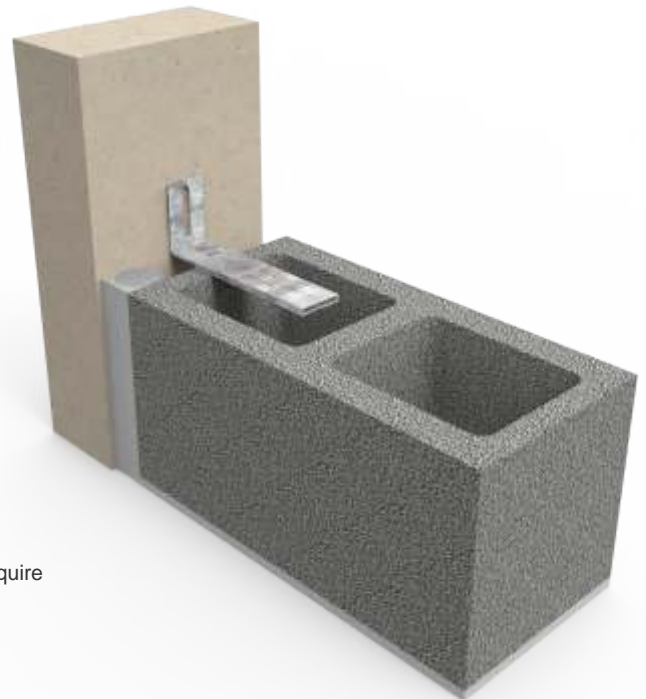

### ORDERING INFORMATION

When ordering please supply use with the part number and quantity you require

**SLIDE-SD01B-2H-R4**

PRODUCT CODE

SLOT / HOLE

MATERIAL

Specify

Specify

2H for holes

R3 for Hot dipped galvanised

S for a slot

R4 for Stainless steel 316L